

SECTION 10 - ELECTRICAL

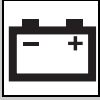



ELECTRICAL

Electrical Components, Upperstructure

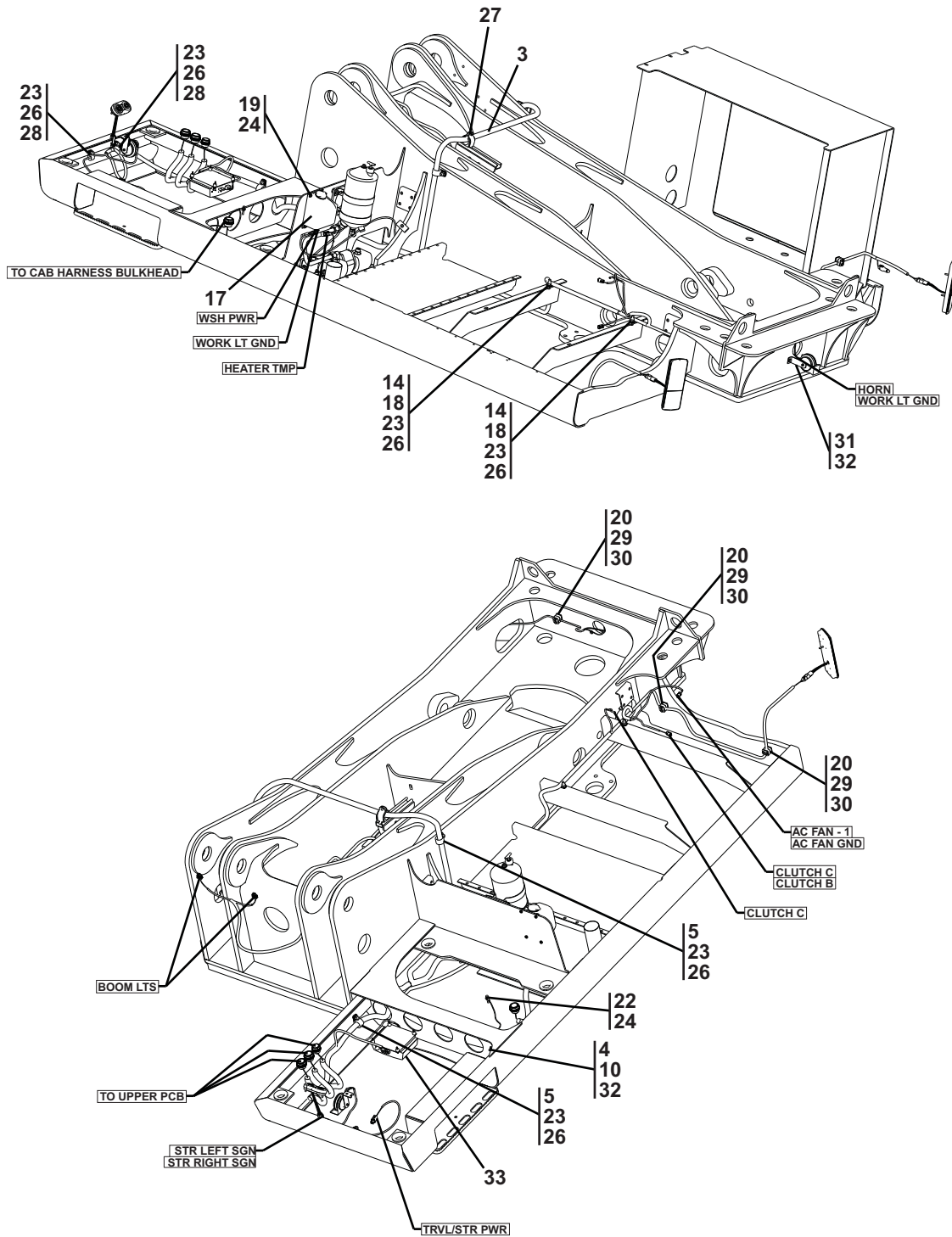

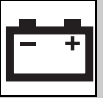

Electrical Components, Upperstructure

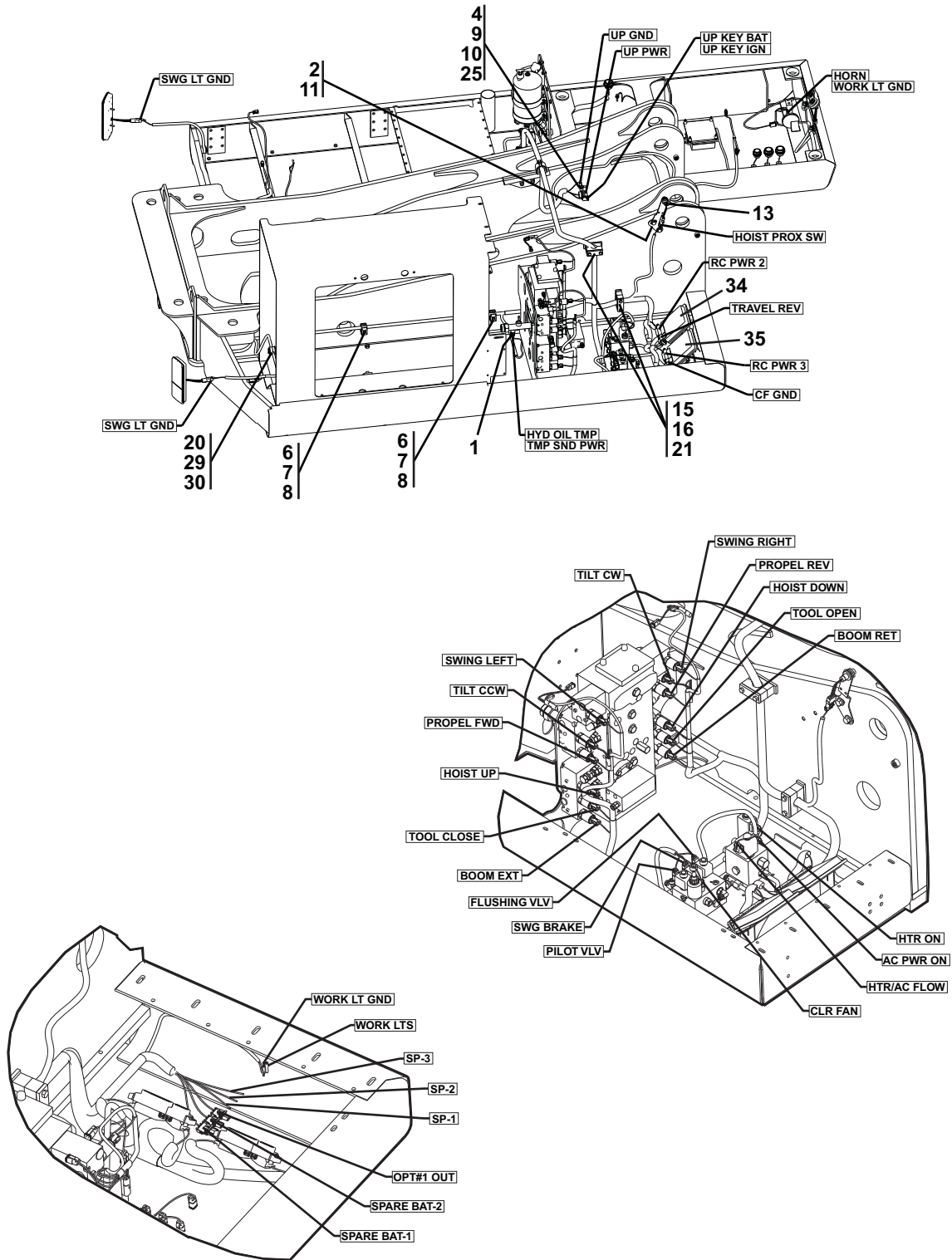



ELECTRICAL

Electrical Components, Upperstructure

Item	Part Number	Qty.	Description	Rev.
1	4000012	1	TEMPERATURE SENSOR	
2	4341189	1	SWITCH SUPPORT	
3	80763094	1	REMOTE UPPER HARNESS	
4		A/R	DI-ELECTRIC GREASE	
5	24601710	2	SUPPORT CLAMP	
6	77133140	2	COVER PLATE	
7	77133168	2	CLAMP SET	
8	77133177	2	HEX HD CAPSCREW, 5/16-18X1-3/8	
9	77143004	1	WHIZ-LOK SCREW, 5/16-18X1-1/4	
10	77143006	2	WHIZ-LOK NUT, 5/16-18	
11	80223034	2	WHIZ-LOCK SCREW, 1/2-13X3/4	
12	80263042	1	GROUND STRAP CABLE	
13	80363166	1	PROXIMITY SENSOR	
14	80973096	2	WHIZ-LOK SCREW, 3/8-16X1-1/2	
15	83251289	2	CLAMP SET	
16	83251291	2	COVER PLATE	
17	80783116	1	WASHER FLUID BOTTLE	
18	85941016	2	SUPPORT CLAMP, 1/2	
19	88201003	4	HEX HD CAPSCREW, 1/4-20X3/4, GR5	
20	88201006	8	HEX HD CAPSCREW, 1/4-20X1/4, GR5	
21	88201042	4	HEX HD CAPSCREW, 3/8-16X2-3/4, GR5	
22	88501004	1	HEX NUT, 1/4-20	
23	88521206	6	HEX LOCKNUT, 3/8-16	
24	88561002	5	FLAT WASHER, 1/4	
25	88561003	1	FLAT WASHER, 5/16	
26	88561004	6	FLAT WASHER, 3/8	
27	90205793	1	CUSHION CLAMP, 1-1/2	
28	91043147	2	SUPPORT CLAMP, 3/4	
29	91063039	4	COVER PLATE CLAMP	
30	91063040	4	CLAMP SET, 3/8	
31	83303239	1	HORN	
32	91363018	2	SCREW, 5/16-18X1	
33		Ref	24V-12V POWER CONVERTER, (see page 7-6 for details)	
34	80763078	1	UPPER CONTROLLER, (RC 6-9)	
35	80763079	1	UPPER EXPANSION CONTROLLER, (RC 12-4)	

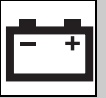

Electrical Components, Upperstructure

Item	Part Number	Qty.	Description	Rev.

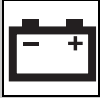

ELECTRICAL

Battery Box Installation

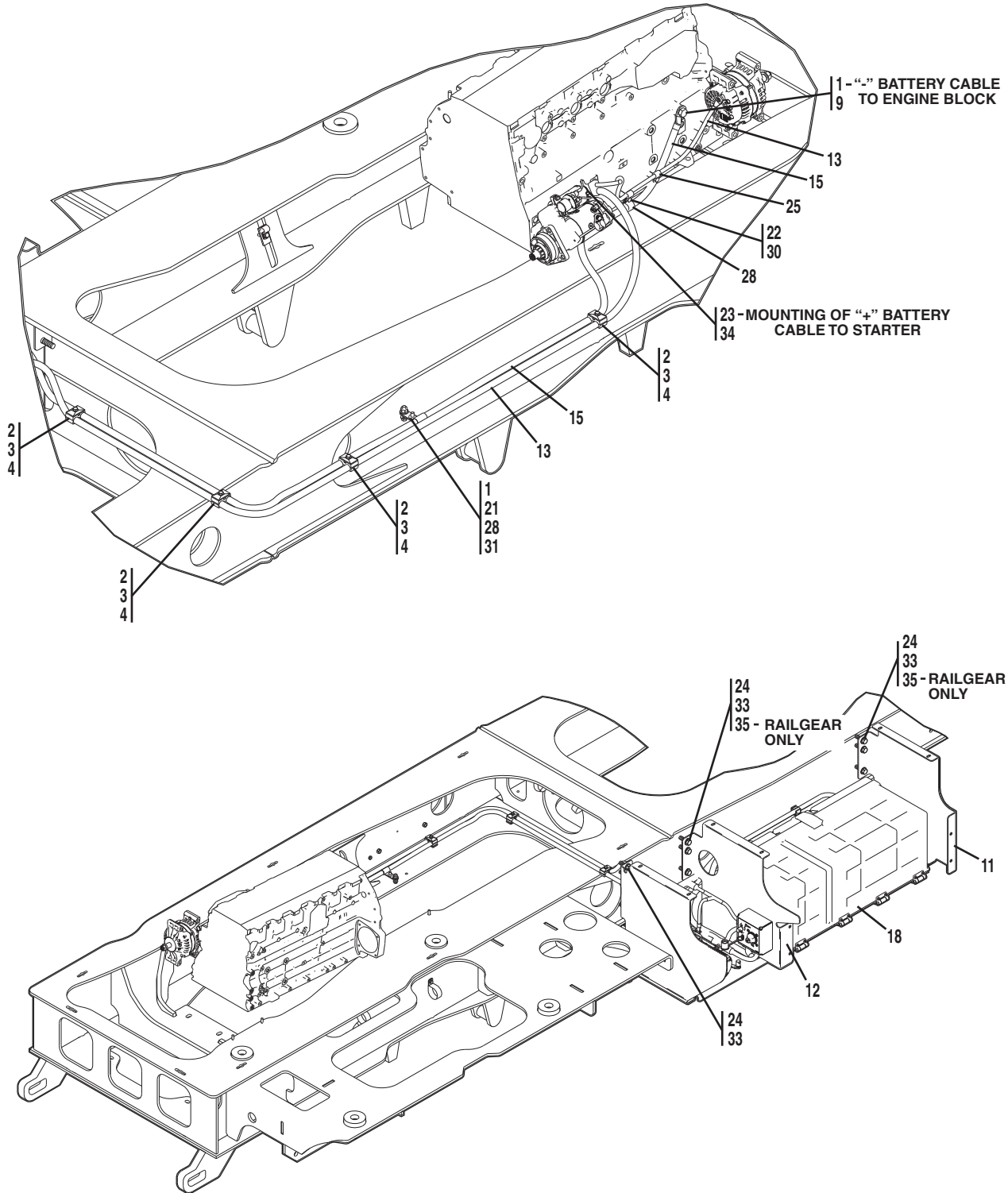

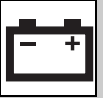

Battery Box Installation

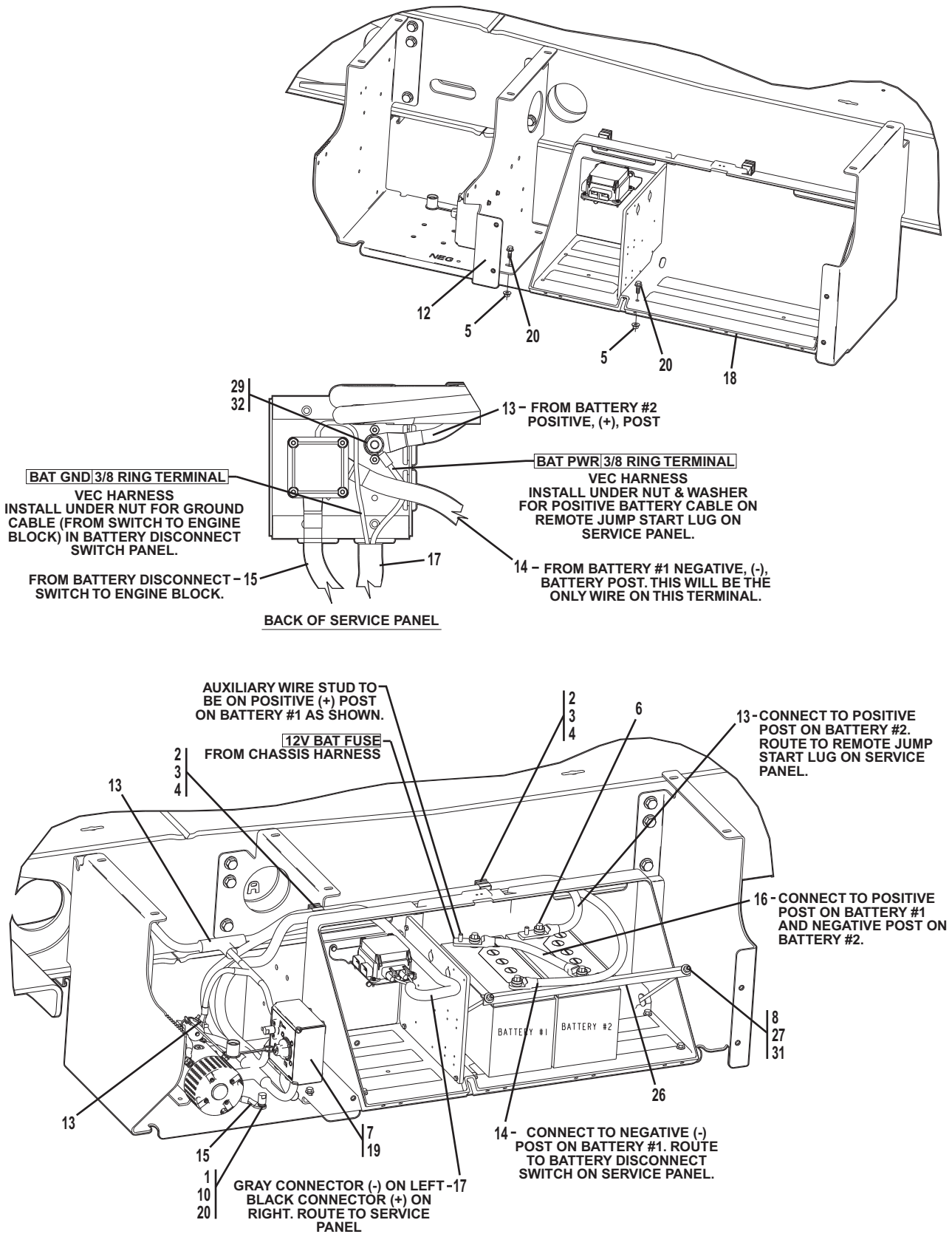



ELECTRICAL

Battery Box Installation

Item	Part Number	Qty.	Description	Rev.
1		A/R	DI-ELECTRIC GREASE	
2	77133139	6	CLAMP SET	
3	77133140	6	COVER PLATE	
4	77133177	6	HEX HD CAPSCREW, 5/16-18X1-3/8	
5	77143015	7	WHIZ-LOK NUT, 3/8-16	
6	77383567	4	STAINLESS STEEL NUT	
7	80263012	4	WHIZ-LOK SCREW, 1/4-20X1/2	
8	80381114	2	HOLD DOWN STUD	
9	80483102	1	HEX HD CAPSCREW, 16-2X25, GR8.8	
10	80773033	1	BRASS BUSHING	
11	80781203	1	BATTERY BOX SUPPORT	
12	80781204	1	INNER SUPPORT PLATE	
13	80783201	1	POSITIVE BATTERY CABLE	
14	80783202	1	NEGATIVE BATTERY CABLE	
15	80783203	1	NEGATIVE BATTERY CABLE	
16	80783204	1	BATTERY JUMPER CABLE	
17	80783205	1	CHASSIS VEC HARNESS	
18		Ref	BATTERY BOX ASSY, (see page 10-10 for details)	
19		Ref	SERVICE PANEL ASSY, (see page 10-12 for details)	
20	80973025	8	WHIZ-LOK SCREW, 3/8-16X1	
21	88201036	1	HEX HD CAPSCREW, 3/8-16X1-1/4, GR5	
22	83191007	3	HEX HD CAPSCREW, 8-1.25X16, GR8.8	
23	83191013	1	LOCKWASHER, M10	
24	83201092	9	HEX HD CAPSCREW, 5/8-11X2, GR8, (qty. 3 for machines equipped with railgear)	
25	85941016	2	SUPPORT CLAMP, 1/2	
26	86841069	1	HOLD DOWN ANGLE	
27	88521205	2	HEX LOCKNUT, 5/16-18	
28	91043147	2	SUPPORT CLAMP, 3/4	
29	88521306	2	HEX LOCKNUT, 3/8-16	
30	88561003	3	FLAT WASHER, 5/16	
31	88561004	3	FLAT WASHER, 3/8	
32	88561109	1	FLAT WASHER, 3/8	
33	90027472	9	HARDENED WASHER	
34	91033134	1	HEX NUT, M10X1.5, (torque to 15-22 lb-ft)	
35	88681455	6	HEX HD CAPSCREW, 5/8-11X1-1/2, GR8, (railgear equipped machines only)	

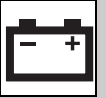

Battery Box Installation

Item	Part Number	Qty.	Description	Rev.

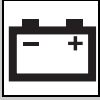

ELECTRICAL

Battery Box Assembly

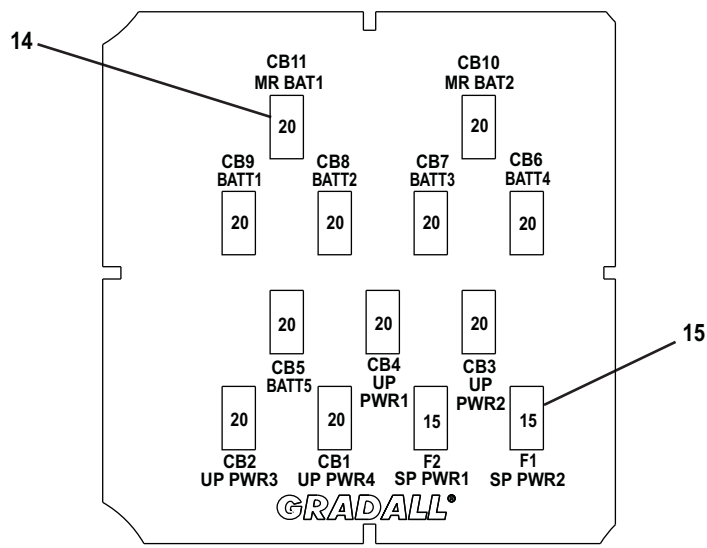
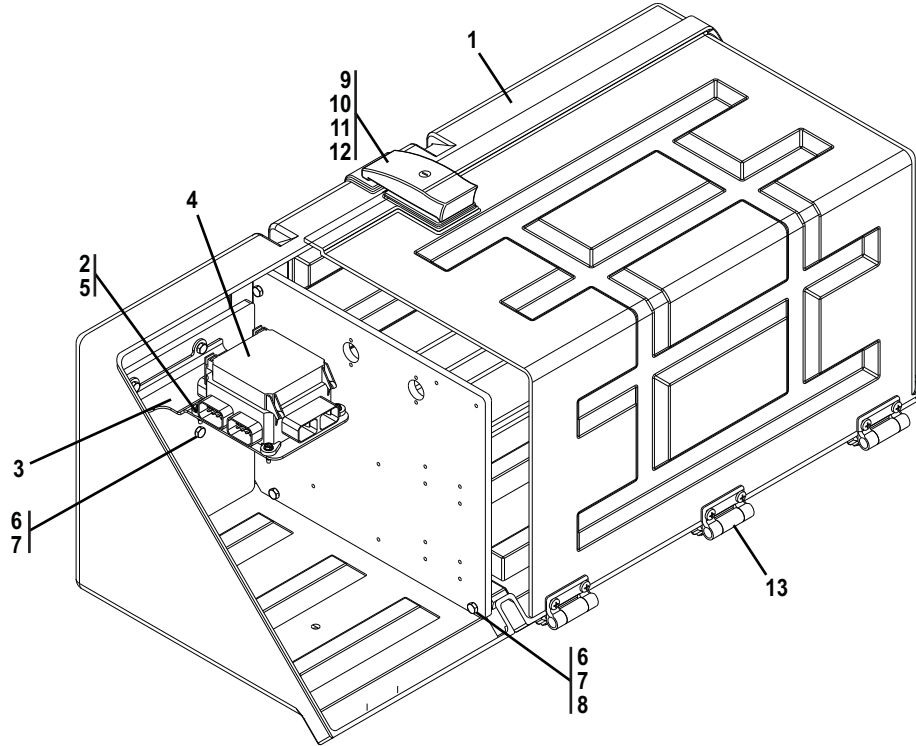

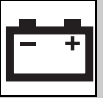

Battery Box Assembly

Item	Part Number	Qty.	Description	Rev.
1	1671325	1	BATTERY BOX, (includes items 9 thru 13)	B
2	77143017	4	WHIZ-LOK NUT, #10-24	
3	80481210	1	VEC BRACKET	
4	80483066	1	BUSSMAN VEC, (includes items 14 & 15)	
5	80483093	4	SELF-TAPPING SCREW, #10-24X3/4	
6	88201005	A/R	HEX HD CAPSCREW, 1/4-20X1, GR5	
7	88521304	A/R	HEX LOCKNUT, 1/4-20	
8	88561107	A/R	FLAT WASHER, 1/4	
9	80304765	1	DRAW LATCH, (non-locking)	
	80383234	1	DRAW LATCH, (locking), (uses key 91404275)	
10	88261010	6	SOCKET BUTTON HD CAPSCREW, #10-24x3/4	
11	88521605	6	HEX LOCKNUT, #10-24	
12	88561105	6	FLAT WASHER, #10	
13	80484046	4	HINGE	
14	80464006	11	CIRCUIT BREAKER, 20AMP, (rated 14-volt)	
15	80464004	2	FUSE, 15AMP	
	80634083	A/R	VEC REPAIR KIT	

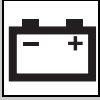

ELECTRICAL

Service Panel Assembly

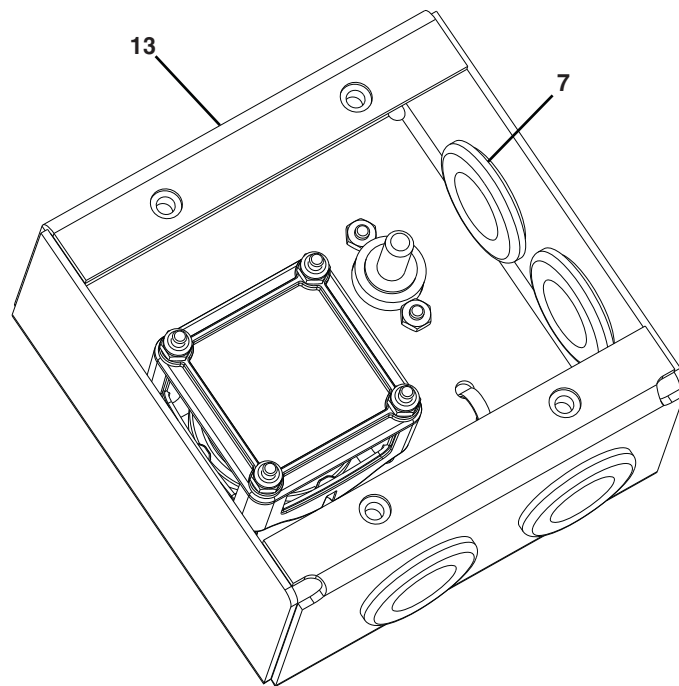
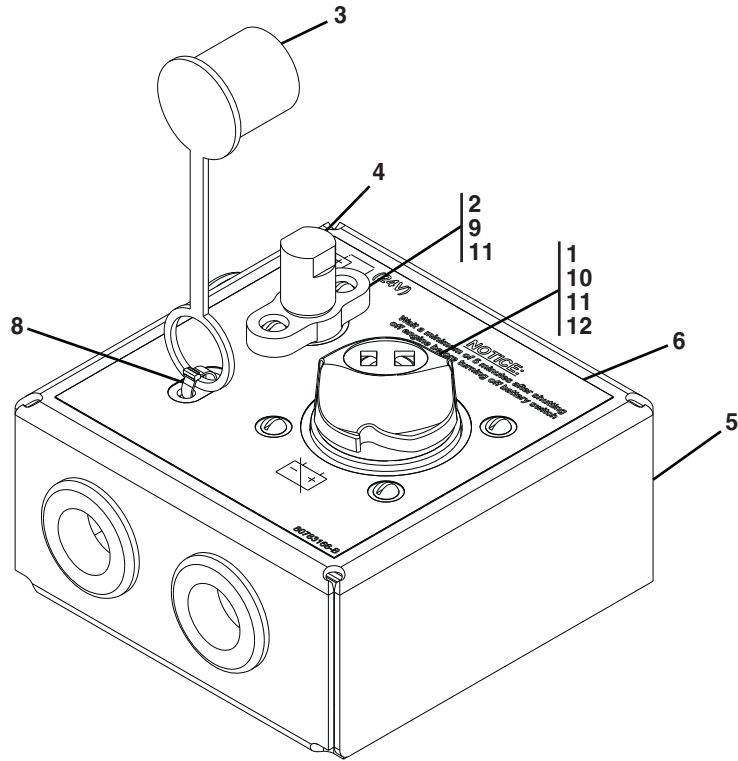

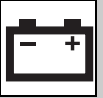

Service Panel Assembly

Item	Part Number	Qty.	Description	Rev.
1	80373133	1	BATTERY DISCONNECT SWITCH	
2	80483061	1	JUNCTION BLOCK	
3	80763013	1	CAP	
4	80773033	1	BRASS BUSHING	
5	80781170	1	SERVICE BRACKET	
6	80783166	1	SERVICE PANEL DECAL	
7	85131075	4	GROMMET, 1"	
8	86683122	1	TIE WRAP	
9	88681605	2	ROUND HD MACHINE SCREW, M5X0.8X12MM, (zinc plated)	
10	88681606	4	ROUND HD MACHINE SCREW, M5X0.8X50MM, (zinc plated)	
11	91033133	6	HEX NUT, M5X0.8, (zinc plated)	
12	88681604	4	HEX LOCKNUT, M5X0.8	
13	80783271	1	BATTERY SHUT-OFF TIMER DECAL	

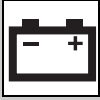

ELECTRICAL

Tail & Marker Lights

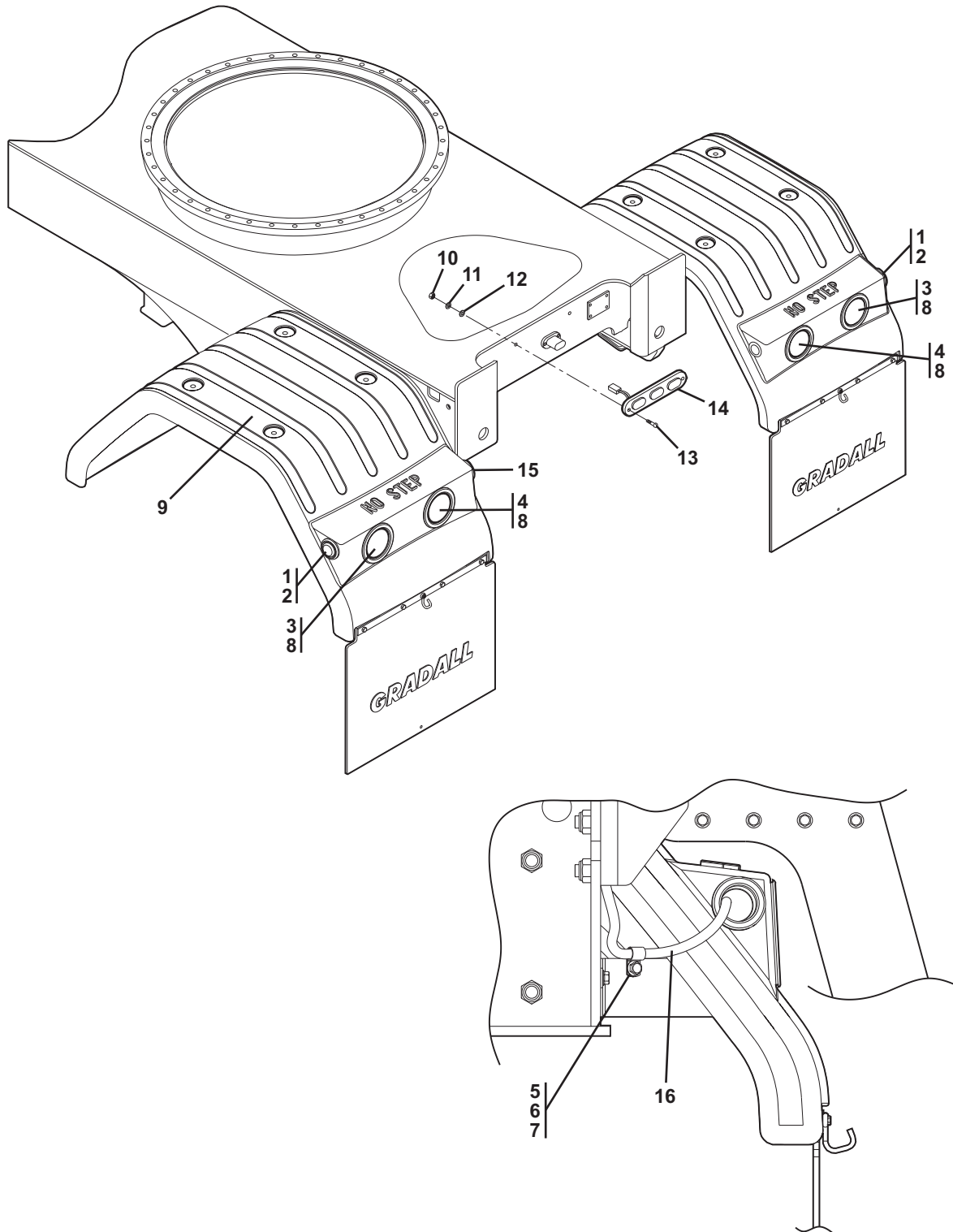

PAC5451

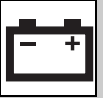

Tail & Marker Lights

Item	Part Number	Qty.	Description	Rev.
1	80783179	2	CLEARANCE LIGHT, RED	
2	80783184	2	LIGHT GROMMET	
3	80783183	2	STOP, TAIL & TURN LIGHT	
4	80783181	2	BACK-UP LIGHT	
5	77143015	2	WHIZ-LOCK NUT, 3/8-16	
6	85841094	2	SUPPORT CLAMP	
7	80973025	2	WHIZ-LOK SCREW, 3/8-16X1	
8	80783185	4	LIGHT GROMMET	
9		Ref	REAR FENDER, (see page 1-20 for details)	
10	88501610	2	HEX NUT, #8-32	
11	88551006	2	LOCKWASHER, #6	
12	88561104	2	FLAT WASHER, #8	
13	88301075	2	ROUND HD MACHINE SCREW, #8-32X1, GR8	
14	80783473	1	REAR ID LIGHT w/CONNECTOR	
15	80383374	2	RUBBER GROMMET	
16	80783193	2	TAIL LIGHT HARNESS	

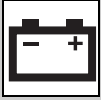

ELECTRICAL

Head & Marker Lights

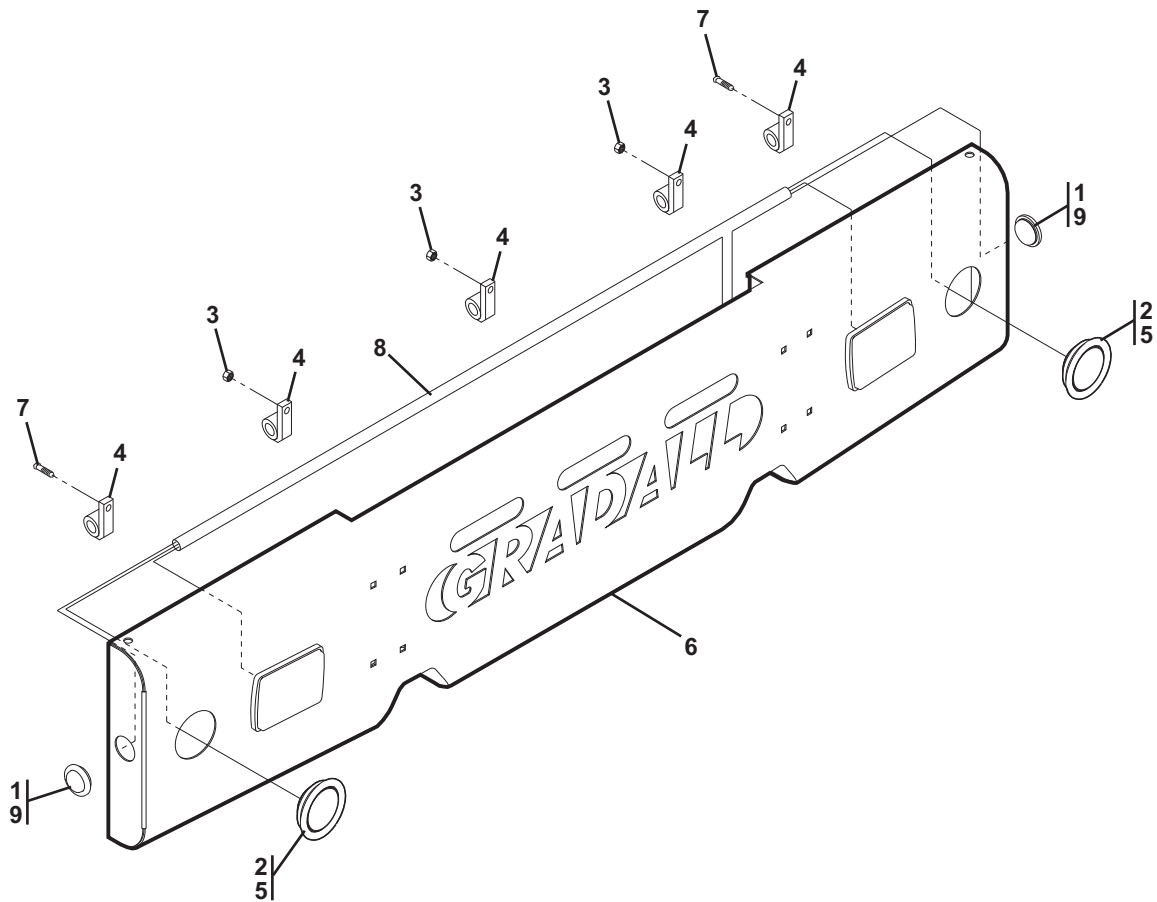

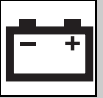

Head & Marker Lights

Item	Part Number	Qty.	Description	Rev.
1	80783180	2	CLEARANCE LIGHT, (amber)	
2	80783185	2	GROMMET	
3	77143006	3	WHIZ-LOK NUT, 5/16-18	
4	85941016	5	SUPPORT CLAMP, 1/2	
5	80783182	2	TURN LIGHT, (amber)	
6		Ref	FRONT BUMPER & HEAD LIGHTS, (see page 1-8 for details)	
7	90027319	2	SELF TAPPING SCREW, 1/4-20	
8	80783192	1	FRONT BUMPER HARNESS	
9	80783184	2	LIGHT GROMMET	
			NOTE: Some machines may use tie-wraps in place of support clamps/hardware. Tie-wraps are an approved replacement for the support clamps, if desired:	
	86683122	A/R	TIE-WRAP	



ELECTRICAL

Cab Console Circuit Board, Upperstructure

NOTE: THE SCHEMATIC SHOWN ON THIS PAGE IS FOR SPARE PARTS IDENTIFICATION. AN ENLARGED, DETAILED VIEW OF THE SCHEMATIC CAN BE FOUND IN THE ASSOCIATED MODEL'S SERVICE MANUAL.

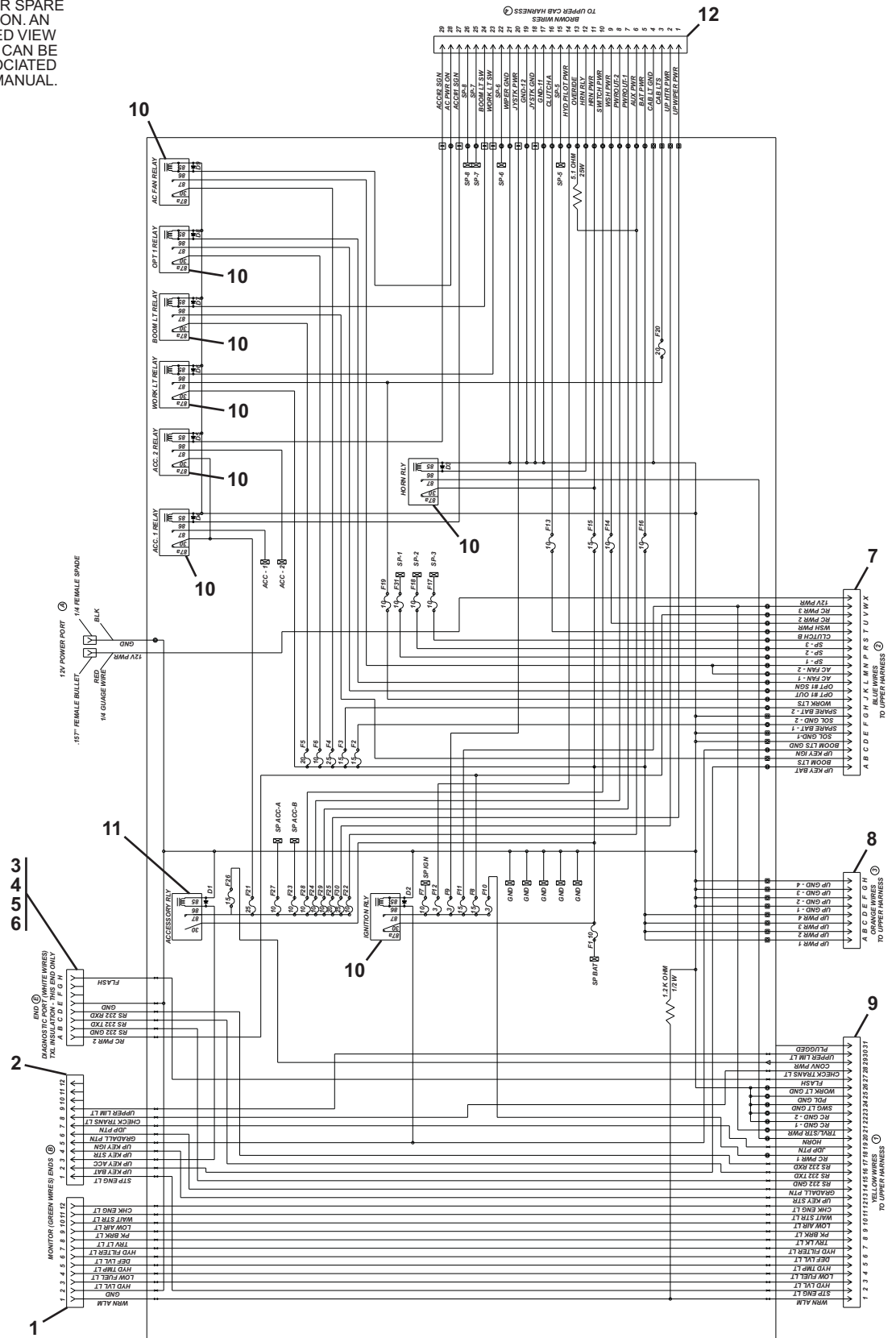

PAC6490

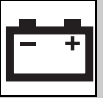

Cab Console Circuit Board, Upperstructure

Item	Part Number	Qty.	Description	Rev.
	80763082	1	UPPERSTRUCTURE CAB CONSOLE CIRCUIT BOARD, (includes all items)	C
1	91504046	1	CONNECTOR	
2	91504100	1	CONNECTOR	
3	80364201	1	HOUSING	
4	80364202	1	STRAIN RELIEF	
5	80364203	1	HOUSING CAP	
6	80364204	1	PIN	
7	80544022	1	CONNECTOR	
8	80544021	1	CONNECTOR	
9	80544020	1	CONNECTOR	
10	80764102	8	RELAY, (24v)	
11	80764101	1	RELAY, (24v)	
12	80544024	1	CONNECTOR	
<p>NOTE: The circuit board is stamped with a part number for a 12-volt system and a part number for a 24-volt system. This machine uses a 24-volt system. If ordering a new circuit board, use part number 80763082 only.</p>				

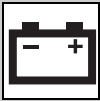

ELECTRICAL

Cab Console Circuit Board, Undercarriage

NOTE: THE SCHEMATIC SHOWN ON THIS PAGE IS FOR SPARE PARTS IDENTIFICATION. AN ENLARGED, DETAILED VIEW OF THE SCHEMATIC CAN BE FOUND IN THE ASSOCIATED MODEL'S SERVICE MANUAL.

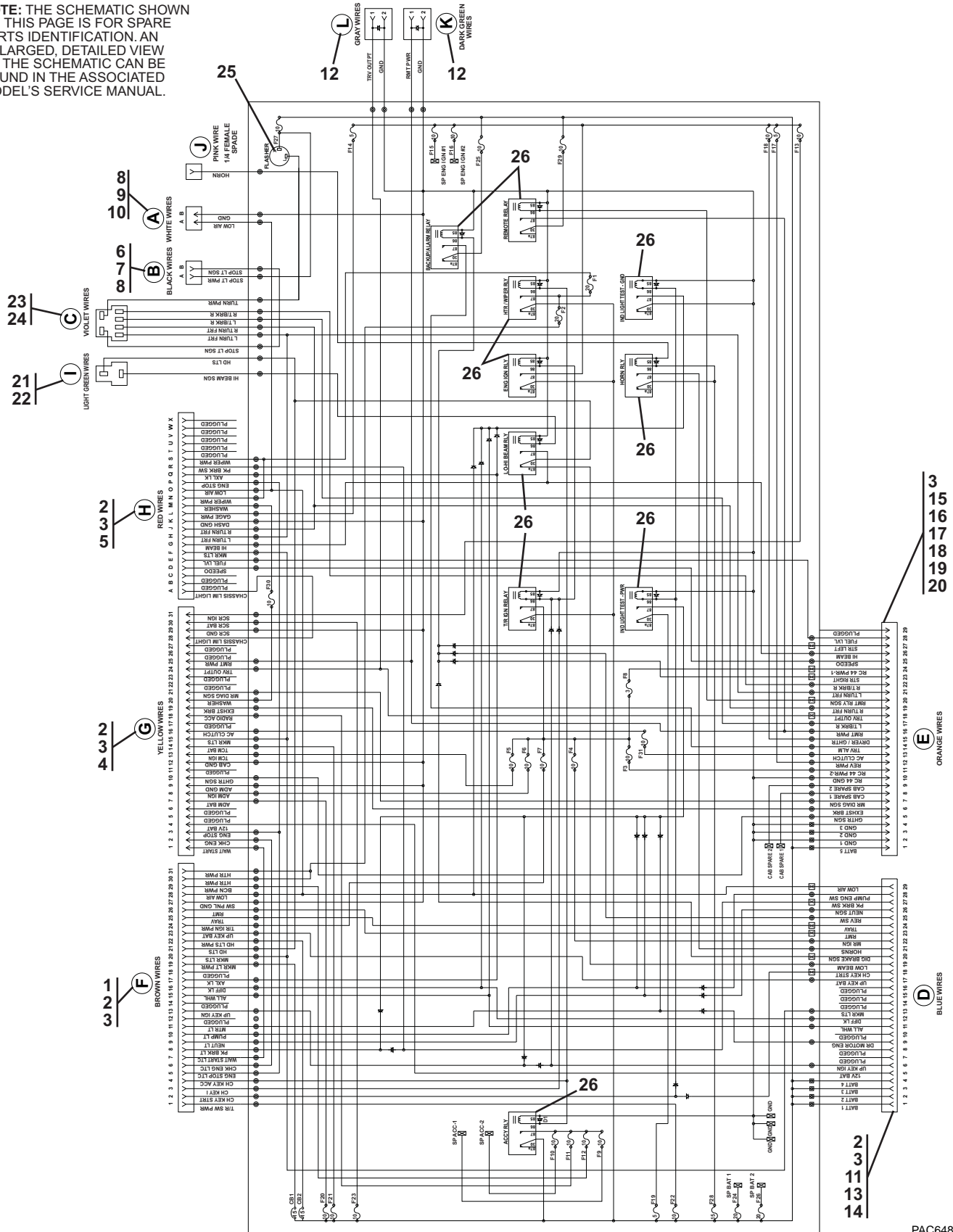

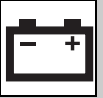

Cab Console Circuit Board, Undercarriage

Item	Part Number	Qty.	Description	Rev.
	80783104	1	UNDERCARRIAGE CAB CONSOLE CIRCUIT BOARD, (includes all items)	B
1	86984550	1	CONNECTOR	
2	77363229	4	PIN CONTACT	
3	77363349	5	PLUG	
4	80544017	1	CONNECTOR	
5	80544018	1	CONNECTOR	
6	80963057	1	WEATHERPACK TOWER, (2-wire)	
7	80963068	2	FEMALE TERMINAL PIN	
8	80963066	2	CABLE SEAL, 16GA., (gray)	
9	80963058	1	WEATHERPACK SHROUD, (2-wire)	
10	80963069	2	MALE TERMINAL PIN	
11	80544016	1	CONNECTOR	
12	77383554	2	CONNECTOR\	
13	77363347	1	CONTACT	
14	80604005	1	CONTACT	
15	80544019	1	CONNECTOR	
16	77363228	1	PIN CONTACT	
17	77363345	1	CONTACT	
18	77363346	1	CONTACT	
19	83481286	1	NUT	
20	83481285	1	LOCKWASHER	
21	86984556	1	TERMINAL	
22	86984555	1	CONNECTOR	
23	86984553	1	CONNECTOR	
24	86984554	1	TERMINAL	
25	80704001	1	FLASHER, 24V	
26	80764102	10	RELAY, 24V	

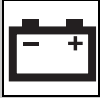

ELECTRICAL

Work Lights Installation

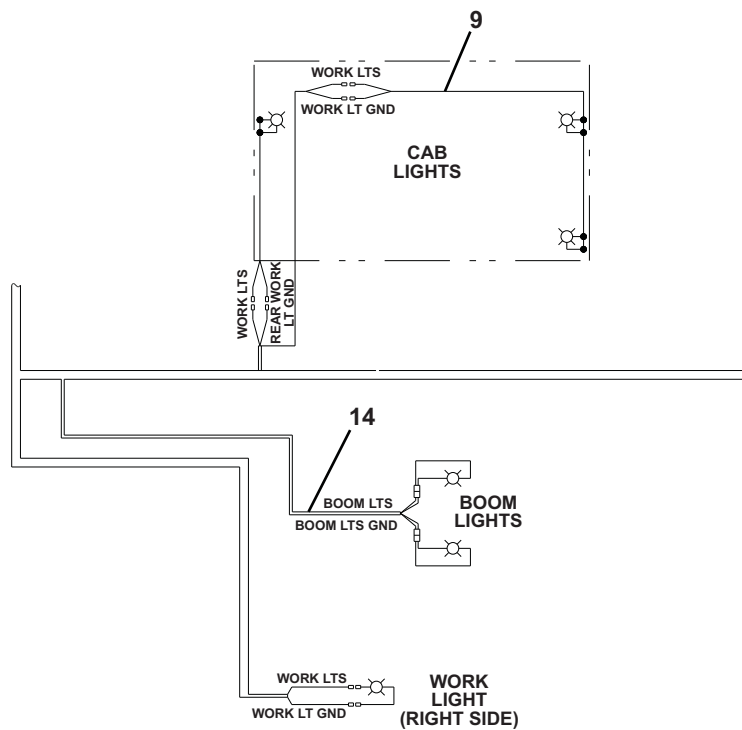
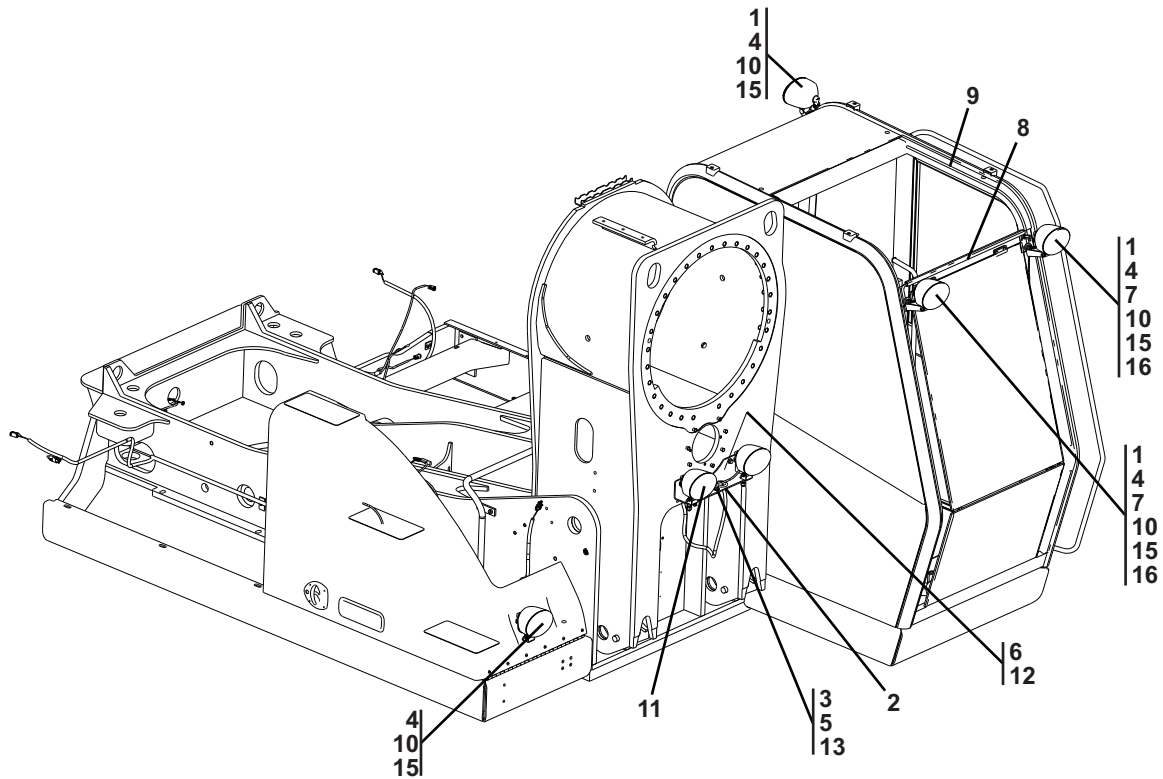

PAC4830

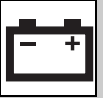

Work Lights Installation

Item	Part Number	Qty.	Description	Rev.
	80739004	Ref	WORK LIGHTS INSTALLATION, (includes all items)	A
1	14404173	A/R	SILICONE CAULK	
2	24921315	1	GROMMET, 1-1/2	
3	77143015	1	WHIZ-LOK NUT, 3/8-16	
4	77163105	4	FEMALE BULLET TERMINAL, .157	
5	80303094	1	WHIZ-LOK SCREW, 3/8-16X3/4	
6	80361029	1	LIGHT BRACKET	
7	80363038	2	WORK LIGHT SPACER	
8	80363040	1	WIRING DUCT	
9	80363094	1	CAB WORK LIGHT HARNESS	
10	80763093	4	FLOOD LIGHT, (includes bulb)	
	80764155	4	FLOOD LIGHT BULB	
11	80763108	2	SPOT LIGHT	
12	80973025	2	WHIZ-LOK SCREW, 3/8-16X1	
13	86621230	1	SUPPORT CLAMP, 11/32	
14	86683122	6	TIE WRAP	
15	86983193	4	MALE BULLET TERMINAL, .157	
16	80761044	2	LIGHT BRACKET	

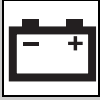

ELECTRICAL

Work Lights (LED) Installation

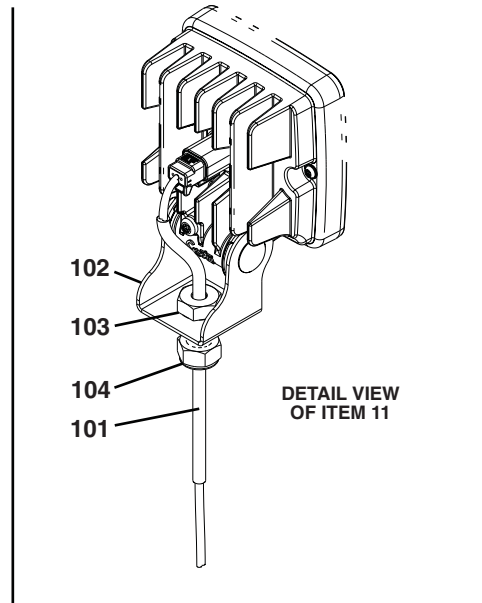
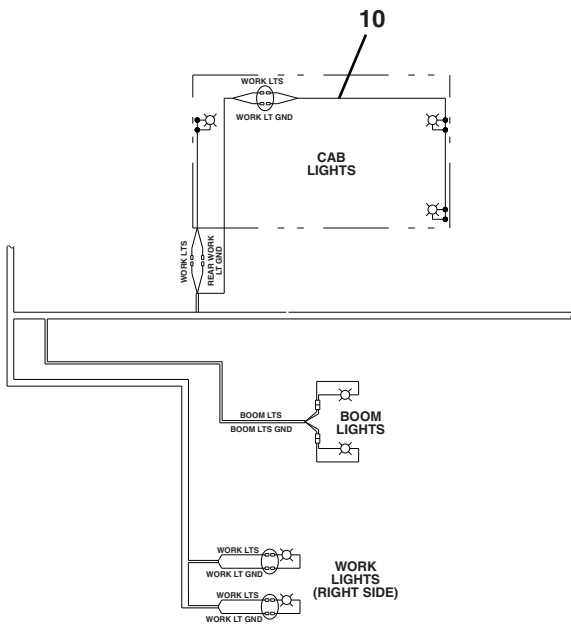
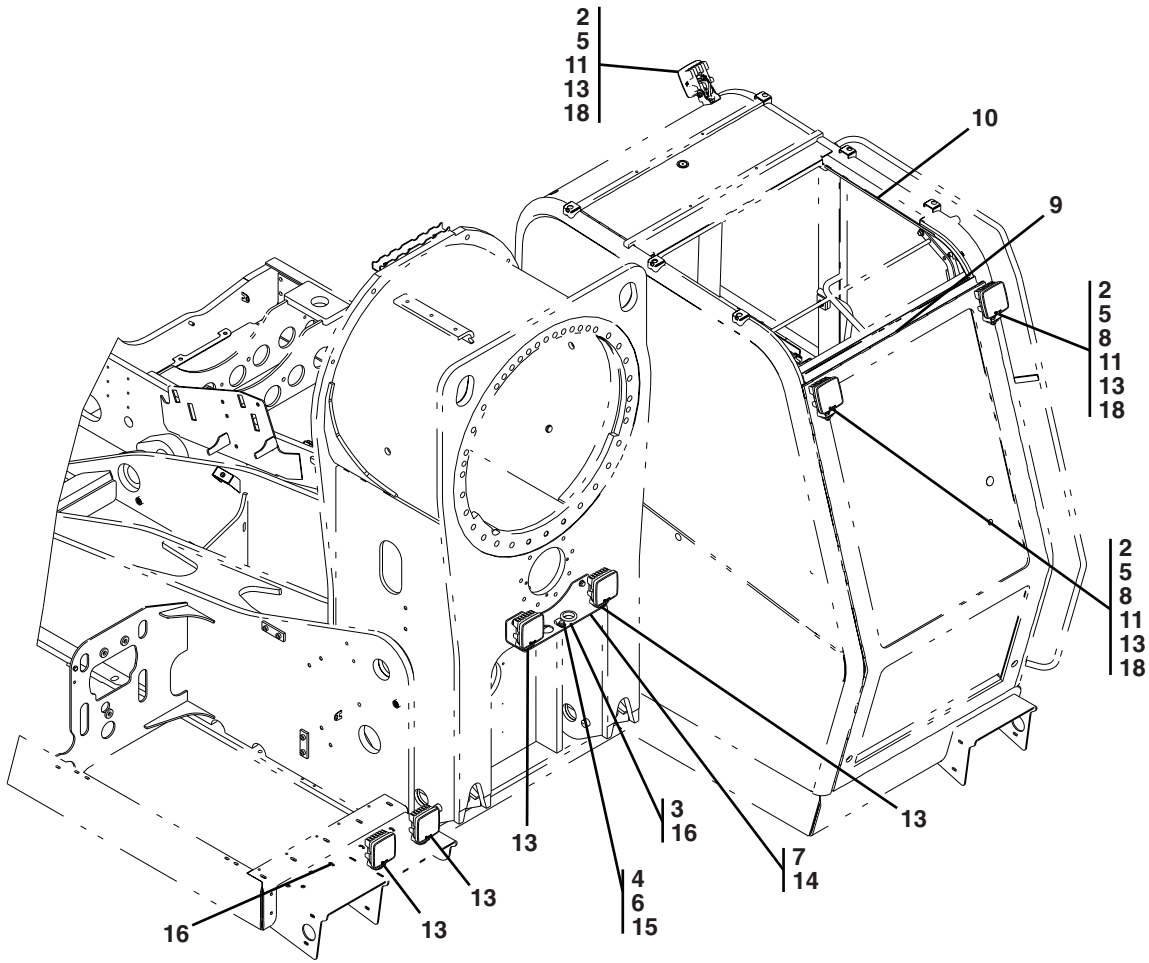

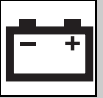

Work Lights (LED) Installation

Item	Part Number	Qty.	Description	Rev.
	80769068	Ref	WORK LIGHTS (LED) INSTALLATION, (includes all items)	A
1	14403364	A/R	LOCTITE, #242 (blue)	
2	14404173	A/R	SILICONE CAULK	
3	24921315	1	GROMMET, 1-1/2	
4	77143015	1	WHIZ-LOK NUT, 3/8-16	
5	77163105	4	FEMALE BULLET TERMINAL, .157	
6	80303094	1	WHIZ-LOK SCREW, 3/8-16X3/4	
7	80361029	1	LIGHT BRACKET	
8	80363038	2	WORK LIGHT SPACER	
9	80363040	1	WIRING DUCT	
10	80363094	1	CAB WORK LIGHT HARNESS	
11	82175010	3	WORKLIGHT HOUSING ASSY, (includes items 101 thru 104)	-
12	<i>Not Used</i>			
13	82173056	7	LED WORKLIGHT	
14	80973025	2	WHIZ-LOK SCREW, 3/8-16X1	
15	86621230	1	SUPPORT CLAMP, 11/32	
16	86683122	9	TY-WRAP	
17	<i>Not Used</i>			
18	86983193	3	MALE BULLET TERMINAL, .157	
101	82173057	1	CABLE ASSY	
102	82171040	1	BRACKET	
103	88681617	1	HEX HD CAPSCREW, 1/2-13X1-1/4 (stainless steel)	
104	88681383	1	NYLOCK NUT, 1/2-13	

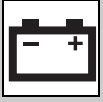

ELECTRICAL

This Page Intentionally Left Blank